

INSTRUCTION MANUAL ECO SCISSOR LIFT

VERSION
MODEL
APPLICABLE PRODUCTS

JUNE 2013
EMSL22N MANUAL PUMP SCISSOR LIFT | EBSL22N BATTERY OPERATED SCISSOR LIFT
EMSL22N, EBSL22N

WARNING: Do not use the unit before reading and understanding these operating instructions.
NOTE: Please catalog the designation of your unit by referencing the I.D. plate located on the unit. Keep for future reference.

FOREWORD

Before operating the scissor lift pallet truck read this ORIGINAL INSTRUCTION HANDBOOK carefully and understand the usage of the truck completely. Improper operation could create danger.

This handbook describes the usage of a scissor lift pallet truck with manual or electric lifting function. When operating and servicing the truck, make sure, that it applies to your type.

 **Chapter 11 describes specialized stipulations and regulations for the American market. Follow these instructions and stipulations if you operate the truck within the American market!**

Keep this handbook for future reference. If this or the warning/ caution labels are damaged or got lost, please contact your local dealer for replacement.

This truck complies, if applicable, with the requirements according to EN 3691-5 (Industrial trucks- safety requirements and verification, part 5), EN 12895 (Industrial trucks- electromagnetic compatibility, only electric lift version), EN 12053 (Safety of industrial trucks- test methods for measuring noise emissions, only electric lift version), EN 1175 (Industrial truck safety – electrical requirements, only electrical lift version), assumed the truck is used according to the described purpose.

ATTENTION:

- Environmentally hazardous waste, such as batteries, oil and electronics, will have a negative effect on the environment, or health, if handled incorrectly.
- The waste packages should be sorted and put into solid dustbins according to the materials and be collected disposal by local special environment protection bureau. To avoid pollution, it's forbidden to throw away the wastes randomly.
- To avoid leaking during the use of the products, the user should prepare some absorbable materials (scraps of wooden or dry duster cloth) to absorb the leaking oil in time. To avoid second pollution to the environment, the used absorbable materials should be handed in to special departments in terms of local authorities.
- Our products are subject to ongoing developments. Because this handbook is only for the purpose of operating /servicing the pallet truck, therefore please have understanding, that there is no guarantee out of particular features out of this handbook.

 **NOTE: On this manual, the left sign means warning and danger, which can lead to death or serious injury if not followed.**

Copyright

The copyright remains with the company, mentioned on the CE- certificate at the end of this document or, if sold within the USA, with the company, mentioned on the company sticker.

TABLE OF CONTENTS

1. CORRECT APPLICATION	3
2. DESCRIPTION OF THE SCISSOR LIFT PALLET TRUCK	4
a. Main components	4
b. Main technical data	5
c. Description of the safety devices and warning labels.....	6
d. Identification plate	7
3. WARNINGS AND SAFETY INSTRUCTIONS	7
4. COMMISSIONING, TRANSPORTING, STORAGE/ REASSEMBLING	8
a. Commissioning – Tiller assembling	8
b. Hydraulic valve adjustment	9
c. Lifting/transporting	10
d. Storage/ Reassembling	10
5. DAILY INSPECTION	10
6. OPERATING INSTRUCTIONS	11
a. Parking.....	11
b. Lifting.....	11
c. Lowering	11
d. Moving.....	11
e. Quick Lift (EMSL22N).....	12
f. Malfunctions	12
7. BATTERY CHARGING AND REPLACEMENT (EBSL22N).....	12
a. Replacement	12
b. Battery indicator	13
d. Charging with Onboard charger (only ACX 10E, optional).....	13
e. Charging with external charger (only ACX 10E, optional).....	14
8. REGULAR MAINTENANCE	15
9. TROUBLE SHOOTING	16
10. HYDRAULIC FLOW DIAGRAM AND CIRCUIT DIAGRAM.....	18
a. Hydraulic flow diagram	18
b. Circuit diagram (EBSL22N).....	18
11. SPECIALIZED STIPULATIONS FOR THE US- AMERICAN MARKET	19
a. Foreword/ Compliance.....	19
b. Description warning labels (US-market only).....	20
12. DECLARATION OF CONFORMITY (valid, if sold within the EU)	22

1. CORRECT APPLICATION

It is only allowed to use this scissor lift pallet truck according to this instruction handbook.

This truck is a manually operated scissor lift pallet truck with manual or electric lifting function designed for transporting of palletized loads, or to be used stationary as a working platform on level ground. It is not suitable for use in potentially explosive locations and hostile environments. Do not lift or carry person and don't use this truck for other purpose than its intended use. A wrong usage can cause human injuries or can damage equipment.

The "operator" or "user" is in the meaning of this instruction handbook is a natural or legal person who uses the truck himself or on behalf it is used. The operator or user must ensure that the truck is used in the design limits. All danger to life or danger to the user, operator or to third parties must be avoided. The operator/ the operating company has to ensure the correct usage and has to ensure, that this truck is used only by staff, which is trained and authorized to use this truck.

 The truck has to be used on substantially firm, smooth, level and prepared surfaces. Driving with the load on slopes is not allowed. The load must be placed approximately on the longitudinal center plane of the truck and must be in satisfactory condition.

The capacity is marked on the identification plate and depending on the version eventually additionally on the capacity sticker. The operator has to consider the warnings and safety instructions.

The scissor lift pallet truck is intended to be used for indoor applications with ambient temperatures between +1°C and + 40°C. Operating lighting must be minimum 50 Lux.

Modification

No modifications or alterations to this scissor lift pallet truck which may affect, for example, capacity, stability or safety requirements of the truck, shall be made without the prior written approval of the original truck manufacturer, its authorized representative, or a successor thereof. This includes changes affecting, for example braking, steering, visibility and the addition of removable attachments. When the manufacturer or its successor approve a modification or alteration, they shall also make and approve appropriate changes to capacity plate, decals, tags and operation and maintenance handbooks. By not observing these instructions, the warranty becomes void.

2. DESCRIPTION OF THE SCISSOR LIFT PALLET TRUCK

a. Main components

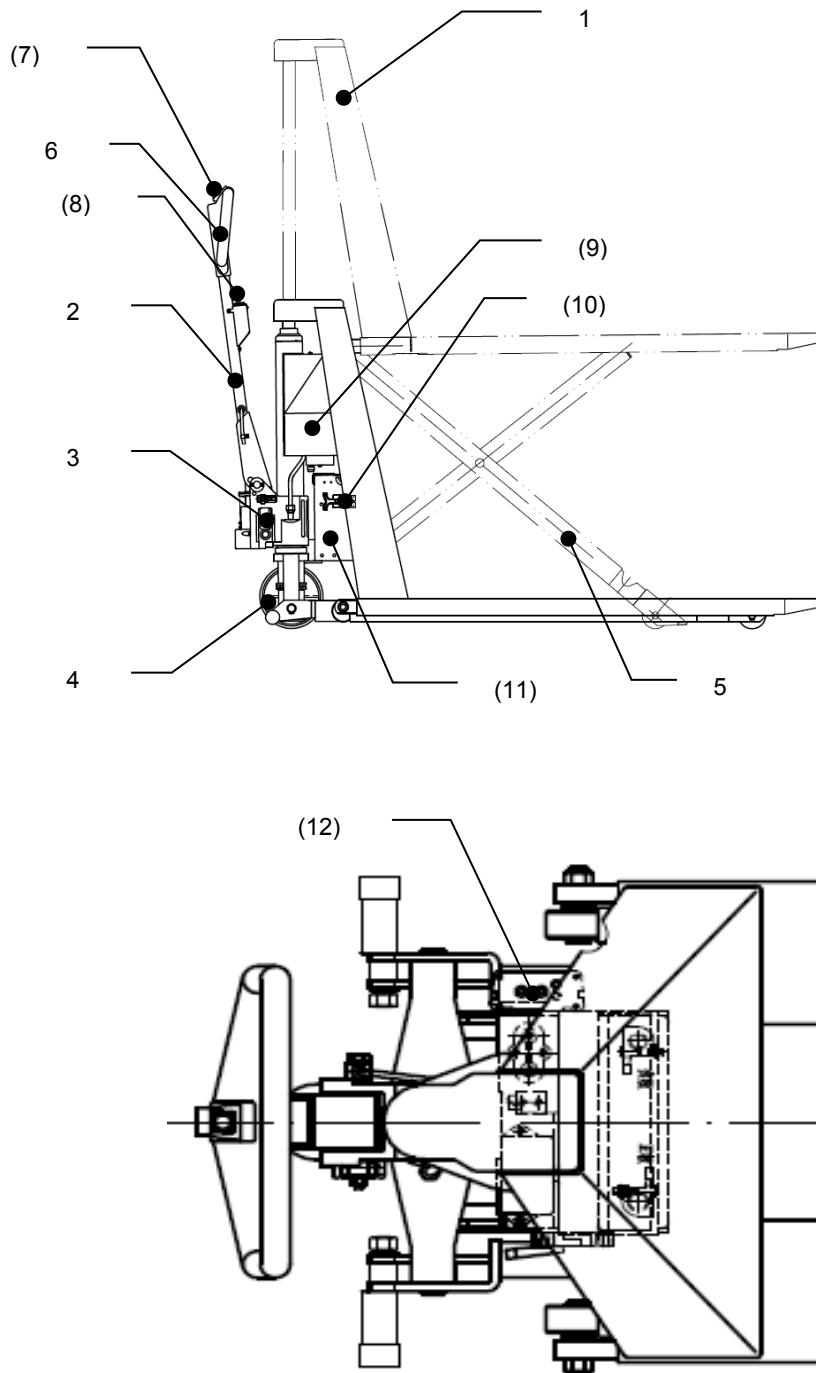

Fig.1: Overview

- | | | | |
|---|------------------------------------|------|----------------------|
| 1 | Chassis | 6 | Control lever |
| 2 | Tiller arm | (7) | Lifting button |
| 3 | Hydraulic cylinder and manual pump | (8) | Key switch |
| 4 | Steering wheel | (9) | Hydraulic power pack |
| 5 | Scissors | (10) | Emergency plug |

(11) Battery (inside)

(12) Onboard charger (optional)

b. Main technical data

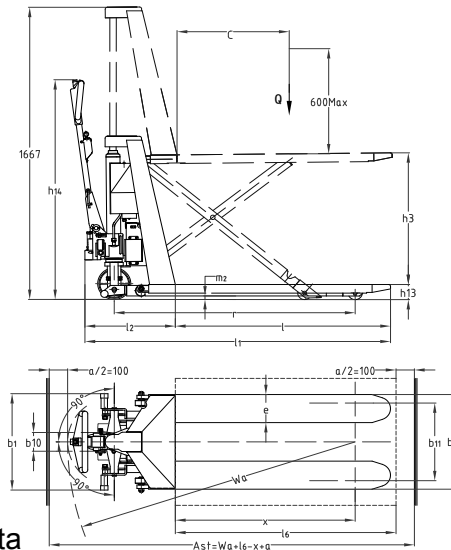

Fig. 2: Technical data

Table 1: Main Technical data for standard version/ other version on request

Technical data sheet for industrial trucks acc. to VDI 2198					
Distinguishing mark	1.2	Manufacturer's type designation		ACX 10E	ACX 10M
	1.3	Drive		Electric	Manual
	1.4	Operator type		hand	hand
	1.5	Load Capacity / rated load	Q(t)	1.0	1.0
	1.6	Load center distance	c(mm)	600	600
	1.8	Load distance ,center of drive axle to	x(mm)	978	978
	1.9	Wheelbase	Y(mm)	1310	1310
Weight	2.1	Service weight incl. battery(see line	kg	152	122
	2.2	Axle loading, laden front/rear	kg	767 / 371	760 / 348
	2.3	Axle loading, un-laden front/rear	kg	35 / 117	33 / 89
Tyres, chassis	3.1	Tires		PU	Pu
	3.2	Tire size, front	mm	Ø180×50	Ø180×50
	3.3	Tire size, rear	mm	Ø 75× 50	Ø 75× 50
	3.4	Additional wheels(dimensions)	mm	—	—
	3.5	Wheels, number front/rear(x=driven		2/ 2	2/ 2
	3.6	Tread, front	b10	155	155
	3.7	Tread, rear	b11	440	440
Dimensions	4.4	Lift (standard mast)	h3 (mm)	715	715
	4.5	Height, mast extended	h4 (mm)	1660	1660
	4.9	Height of tiller in drive position	h14(mm)	1254	1240
	4.1	Height, lowered	h13	85	85
	4.1	Overall length	l1 (mm)	1715	1725
	4.2	Length to face of forks	l2 (mm)	492	492
	4.2	Overall width	b1 (mm)	575/ 695	575/ 695
	4.2	Fork dimensions	s/e/l	45/160/1170	45/160/1170
	4.2	Distance between fork- arms	b5 (mm)	540/ 685	540/ 685
	4.3	Ground clearance, center of	m2 (mm)	18	18
	4.3	Aisle width for pallets 800X1200	Ast	1986	1986
4.3	Turning radius	Wa	1564	1564	
Performance data	5.2	Lift speed, laden/ un-laden	m/s	21/45	—
	5.3	Lowering speed, laden/ un-laden	m/s	53/63	81/61
Electric data	6.2	Lift motor rating at S3 15%	kW	0.58	—
	6.3	Battery acc. to DIN 43531/ 35/ 36 A, B,		No, maintenance-free	—
	6.4	Battery voltage, nominal capacity K5	V/Ah	12V/52Ah	—

Note: black value is our lift pallet trucks' value

c. Description of the safety devices and warning labels

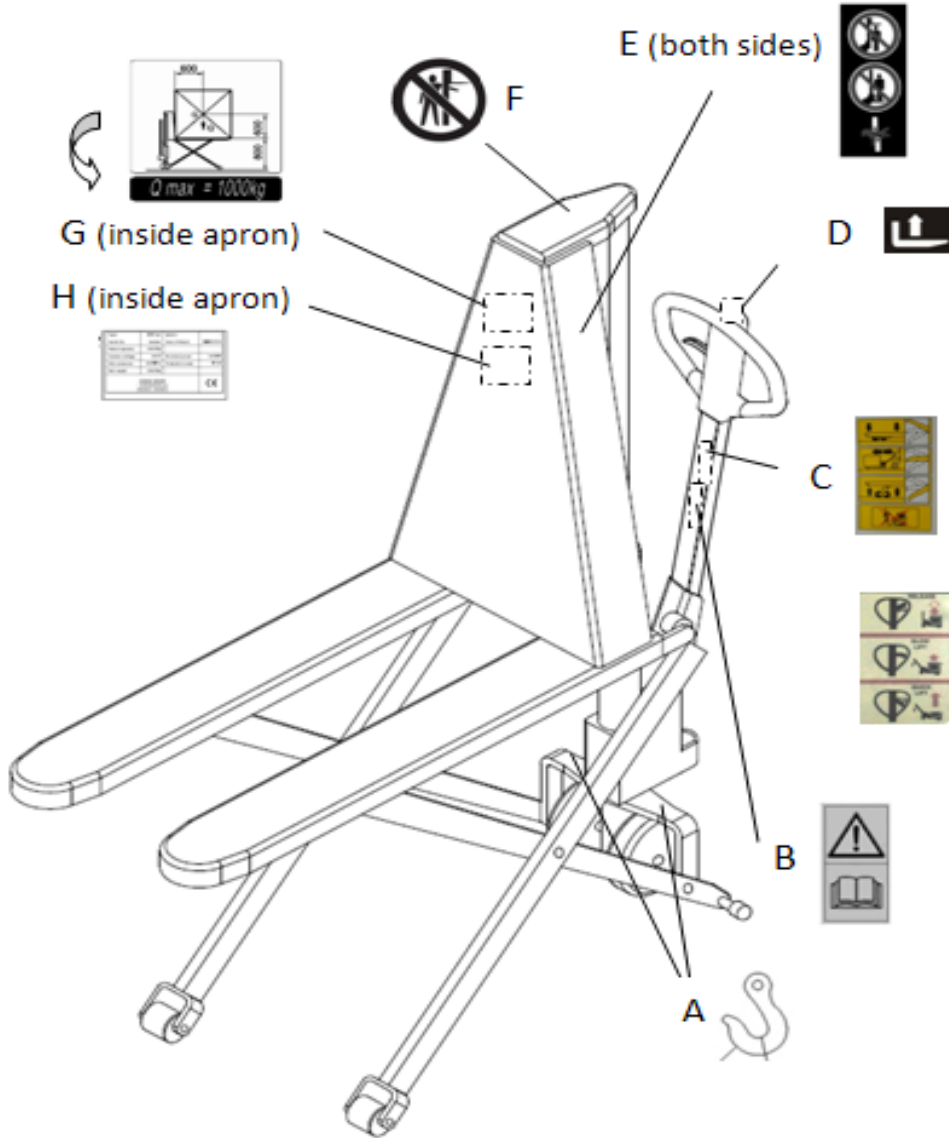

Fig.3: Safety and warning labels

- A Crane hook label
- B Sticker to read and follow these instructions
- C Operating instruction sticker
- D Lifting sign (only EBSL22N)
- E Warning decal: Do not step under or on the forks
- F Never reach through
- G Load diagram
- H Identification plate

The safety and warning labels should be placed according to figure 3. The warnings on the truck are additional to

this handbook. Please follow the operating instructions. If the decals are damaged or missing, please replace them.

d. Identification plate

- 1 Type
- 2 Serial number
- 3 Rated capacity
- 4 System voltage
- 5 Net weight with/without battery
- 6 Name and address of the manufacturer
- 7 Battery mass min/max
- 8 Nominal power
- 9 Load center distance
- 10 Manufacturing date
- 11 Option, Wheel combination, fork length, width over the fork
- 12 Net weight

1	Type	ACX 10E	Option	yyy x1150	
2	Serial No.	xxxxx	Year of Manuf.	MM/YYYY	11
3	Rated capacity	xxxx kg	Load center distance	600mm	10
4	System voltage	xx V	Nominal power	xx kW	9
5	Net weight with/ without battery	yyy/ xxx kg	Battery mass min/max	xxx / xxx kg	8
6	COMPANY NAME COMPANY ADDRESS			CE	7

If sold to the EU, here the place of the CE marking

1	Type	ACX 10M	Option	yyy x1150	
2	Serial No.	xxxxx	Year of Manuf.	MM/YYYY	11
3	Rated capacity	xxxx kg	Load center distance	600mm	10
12	Net weight	xxx kg			9
6	COMPANY NAME COMPANY ADDRESS			CE	

If sold to the EU, here the place of the CE marking

Fig. 4: ID-Plate (electrical, manual)

3. WARNINGS AND SAFETY INSTRUCTIONS



- Allow other person then the operator to stand in front of or behind the truck when it is moving or lifting/lowering.
- Overload the truck.
- Put foot in front of rolling wheel, Injury could result.
- Use the truck on a slope or inclined surface, the truck may become uncontrollable and create danger.
- Lift or carry people. People could fall down and suffer severe injury.
- Use truck with unstable, unbalanced loosely stacked load.
- Use the truck in explosive atmospheres.
- Pay attention for wind forces. Wind forces might have an influence to the stability or light

weights might fall down. Don't use the truck if you can't ensure the stability of the truck.

Watch difference in floor levels when moving the truck. Load could fall down or the truck could get uncontrollable. Keep watching the condition of load. Stop operating table if load becomes unstable. Practice maintenance work according to regular Inspection. This truck is not designed to be water resistant, therefore use it in dry atmospheres.

2. 4. COMMISSIONING, TRANSPORTING, STORAGE/

REASSEMBLING

a. Commissioning – Tiller assembling

After receiving our new scissor lift pallet truck you may have to do following before firstly operating the truck:

- Check if are all parts included and not damaged
- Do the work according to the daily inspections as well as functional checks.
- Eventually assemble the truck according to following instructions.

The commissioning weight is approximately 10kg / four-pack higher than the product weight.

Before assembling, please make sure, that the following supplied parts are included and not damaged:

- 1 pc axle with hole (4)
- 2 pc dowel pin (5) [one is already assembled with the axle]
- 1 pc pre- assembled tiller arm (1)
- 1 pc pre- assembled chassis with pump unit (6)
- Connect the plug (optional for electric model) (Fig. 1, pos. 10)

Note: The marked number on the tiller arm package and the chassis should be the same.

When attaching the handle, you had better squat just in front of the pallet truck.

a) Insert the tiller arm(1) into the pump piston, then use a hammer to insert the axle with hole into the hydraulic pump and tiller arm from the right to the left (Fig. 6).

b) Set the control lever of the handle to the 'LOWER' position, then pass the adjusting nut, adjusting bolt through the hole of the axle with your hand (Fig. 7).

c) Press the tiller arm down; take away the pin (2, Fig. 5).

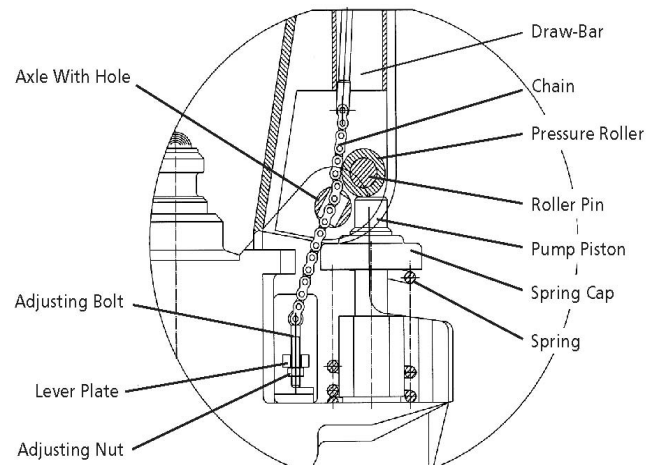

Fig. 7: Side view

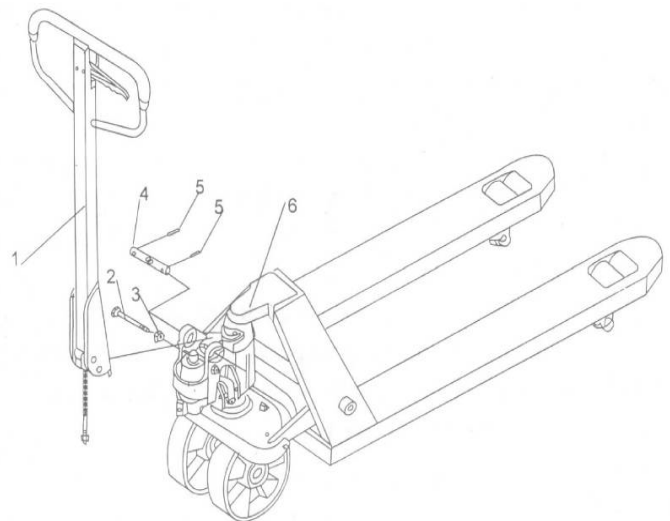

Fig.5 Tiller assembling (symbolic)

(1 Tiller arm / 2 Pin / 3 Nut / 4 Axle with hole / 5 Dowel pin / 6 Chassis with pump unit)

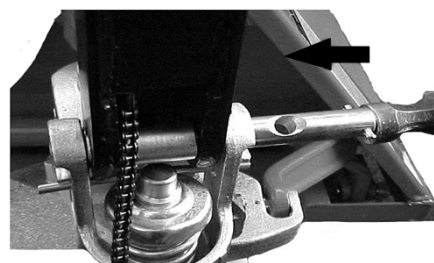

Fig. 6: Axle assembling

d) Set the control lever of the handle to 'QUICK LIFT' (LIFT) position, then raise the lever plate with the pin (2, Fig. 5) and insert the adjusting bolt into the front slot of lever plate. Note: Keep the adjusting nut under the lever plate.

e) Use a hammer to insert the 2nd dowel pin (5, Fig. 5) into the 2nd hole of the axle.
The draw-bar is now assembled to the pump.

For the ENSL22N connect the control cable. Fix the cable at the pump side in a way that the cable holder can be turned. Fix the cable before the plug with the pre assembled cable strip.

b. Hydraulic valve adjustment

On the tiller of your pallet truck, you will find the control lever, which can be regulated in three positions:

a) Lever (EMSL22N)

- Lower** : handle up, the lever moves back to the neutral when released
- Slow lift** : handle in center position
- Quick lift** : handle down

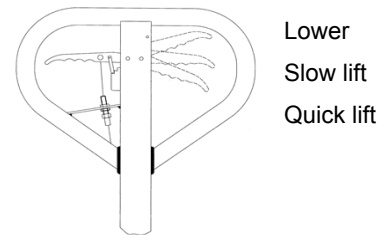

Fig. 8: Lever EMSL22N

If necessary, you can adjust the lever according to following steps (Fig. 8):

- If the forks do not elevate while the control handle is in the **Slow Lift** position or **Quick Lift** position, turn the adjusting nut on the adjusting bolt counter-clockwise until the **Slow Lift** position and the **Quick Lift** position work properly.
- If the forks do not lower down while the control handle is in the **Lower** position, turn the adjusting nut clockwise until the **Lower** position works properly.
- If the forks do not lift slowly when the control handle is in the **Slow Lift** position, turn the adjusting nut clockwise until the **Slow Lift** position works properly.
- If the forks do not lift quickly while the control handle is in the **Quick Lift** position, turn the adjusting nut counter-clockwise until the **Quick Lift** position works properly.

b) Lever (EBSL22N)

- Lower** : handle up, the lever moves back to the neutral
- Neutral** : handle in center position
- Lift** : handle down

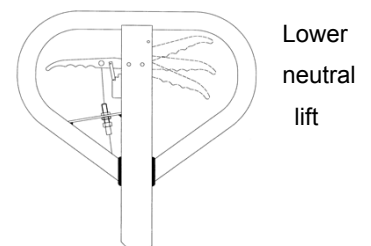

Fig. 9: Lever EBSL22N

If necessary, you can adjust the lever according to following steps (Fig. 9):

- If the forks elevate while pumping in the **Neutral** position, turn the adjusting nut on the adjusting bolt clockwise until pumping action does not raise the forks and the **Neutral** position works properly.
- If the forks descend while pumping in the **Neutral** position, turn the adjusting nut counter-clockwise until the forks do not lower.
- If the forks do not descent when the control handle is in the **Lower** position, turn the adjusting nut clockwise until raising the control handle lowers the forks. Then check the **Neutral** position according to

fig. 9 and be sure that the adjusting nut is in the proper position.

- If the forks do not elevate while pumping in the **Lift** position, turn the adjusting nut counter-clockwise until the forks elevate while pumping in the **Raise** position. Then check the **Lower** and **Raise** position.

C. Lifting/ Transporting

Lifting

USE DEDICATED CRANE AND LIFTING EQUIPMENT



DO NOT STAND UNDER THE SWAYING LOAD
DO NOT WALK INTO THE HAZARDOUS AREA
DURING LIFTING

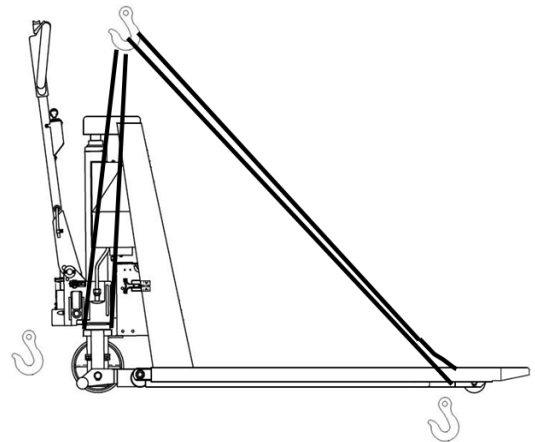

Fig. 10: Lifting with a crane

Park the truck securely and lash the truck according to the points identified in fig. 10. Lift the truck to its destination and place the truck securely before removing the lifting gear. The lashing points are according to the fig. 10

Transportation

For transportation, remove the load, lower the truck to the lowest position and lash it safe with dedicated lashing straps.

d. Storage/ Reassembling

For storage, remove the load, lower the truck to the lowest position, grease all in this handbook mentioned greasing points (regularly inspection) and eventually protect the truck against corrosion and dust. Jack the truck safety, so that there will be no flattening after storage. Reassemble the tiller in the opposite direction of the assembling.

5. DAILY INSPECTION

This chapter describes pre-shift checks before putting the truck into operation.

Daily inspection is effective to find the malfunction or fault on the truck and can maximize the lifetime.

Check the truck on the following points before operation.

Remove load from truck and lower the forks to the lowest position.



DO NOT USE THE TRUCK IF ANY MALFUNCTION OR FAULT IS FOUND.

- Visually check for structural deformation or cracks of arms, forks, or any other component; and unusual noise or binding of the lifting mechanism.
- Check if there is any oil leakage.
- Check the vertical creep of the lifting mechanism.
- Check the smooth movement of the wheels.

- Check if there are any particles or damages on the wheels.
- Check if all the bolts and nuts are tightened firmly.
- If equipped, check the brake.
- Verify that all labels are in place.

6. OPERATING INSTRUCTIONS

- When operating the truck, the operator has to wear safety shoes.
- The truck is intended to be used for indoor applications with ambient temperatures between +5°C and + 40°C.



- The operating lighting must be minimum 50 Lux.
- It is not allowed to use the truck on angled surfaces.
- Never leave a loaded pallet truck unattended.

a. Parking

Lower the forks to the lowest position and park the scissor lift pallet truck on a smooth and even level ground where the truck not disturbs any other operations. If equipped with a brake use the brake for parking the truck acc. to the description further below.

b. Lifting

Check that the load does not exceed the loading capacity of the pallet truck. Roll the pallet truck with its forks slowly under the pallet/load until the back end of the fork rests against the load (Fig.11). Shift the operating lever down to the Lifting position. Lift the load by up- and down movements of the tiller arm. The load must be evenly distributed across both forks.

The truck is equipped with 2 supports. At a height of approx. 400 mm (15.7”), the supports automatically set on the floor. Once the supports are in place, further movement is not possible.

For the electric version press the lifting button (Fig. 1, pos. 9) to perform the lifting function.

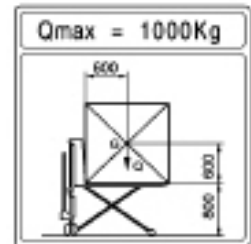

Fig.11: Load conditions



DO NOT OVERLOAD THE TRUCK!

c. Lowering



DO NOT PUT FOOT OR HAND UNDER OR INTO THE LIFTING MECHANISM.

Lower the load by shift the operating lever up to the lowering position carefully. By releasing the lever, the lowering movement will stop. Ensure there is adequate clearance behind, and then move the pallet truck away.

Lowering can also be achieved by the pedal on the side of the truck.

d. Moving



- Do not operate the truck on a slope or inclined surface.
- Watch difference of floor level when moving lifter. Load could fall down
- Make the load stable to prevent it from falling down.
- The truck might be not equipped with a brake. In this case the braking distance is longer and depends on the operator.

If equipped, release the brake.

Move the truck by pushing or pulling the tiller arm. The tiller arm is connected to the steering rollers. The wheels are steered automatically by moving or steering the tiller arm.

e. Quick Lift (EMSL22N)

When the lever is in the down position, it facilitates quick lifting. When handle the lever in neutral position, it facilitates slow lifting.

f. Malfunctions

If there are any malfunctions or the truck is inoperative, please stop using it. Place the truck at a safe place and avoid further usage.

Inform immediately the manager and, or call your service.

7. BATTERY CHARGING AND REPLACEMENT (EBSL22N)



- Only qualified personnel are allowed to service or charge the batteries. The instructions of this handbook and from the battery- manufacturer must be observed.
- These batteries are maintenance free; re- filling is prohibited.
- Recycling of batteries undergoes national regulations. Please follow these regulations.
- By handling batteries, open fire is prohibited, gases could cause explosion!
- In the area of battery charging neither burning materials nor burning liquids are allowed. Smoking is prohibited and the area must be ventilated.
- Park the truck securely before starting charging or installing/changing the batteries
- Before finishing the maintenance work, make sure, that all cables are connected correctly and that there are no disturbing towards other components of the truck.
- EBSL22N: 1 pc 12 v/52Ah



IT IS ONLY ALLOWED TO USE SEALED LIQUID ACID BATTERIES.

THE WEIGHT OF THE BATTERIES HAS AN INFLUENCE TO THE TRUCKS OPERATING BEHAVIOR.

PLEASE CONSIDER THE MAXIMUM OPERATING TEMPERATURE OF THE BATTERIES.

a. Replacement



FOR REPLACEMENT YOU NEED TO LIFT THE TRUCK. BLOCK THE SCISSOR MECHANISM AGAINST LOWERING!

Park the truck securely and switch off the truck with the key switch (Fig. 1, pos. 7) and remove the emergency plug (Fig. 1, pos. 9). Loosen the upper cover with the 2 screws. Also remove the backside fixing bar (also with 2 screws). Disconnect the terminals (Fig. 12) and take the battery out.

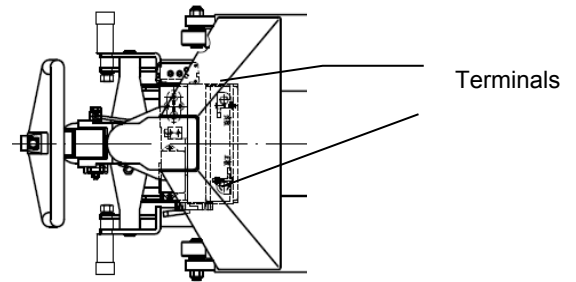
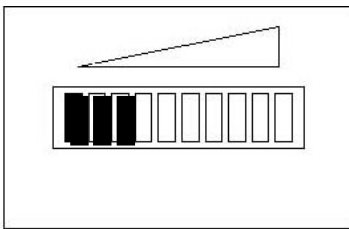

Fig. 11: Battery replacement

The installation is in the reverse order of the removal. Please connect the positive terminals firstly; otherwise the truck could be damaged.

b. Battery indicator

Discharge status is indicated by ten red LED segments.



Battery discharged

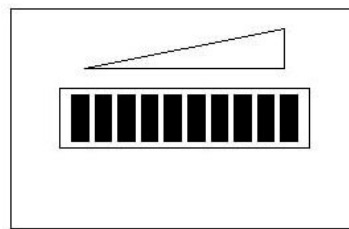

Battery full charged

Fig.13: Battery discharge indicator

- When the battery is properly charged, all LED lights. During discharge successively less LEDs lights up.
- When the most 3 left LEDs lights, the battery is fully discharged. The battery must be charged before further operations, otherwise the lifetime of the battery will be reduced and/or the battery could be damaged!

c. Charging with Onboard charger (only EBSL22N, optional)



- The attached automatic charger is only available for the optional voltage of 110V or 220V as referred.
- The room, where you are charging must be ventilated.
- The exactly charge status can be only checked from the discharge indicator. To control the status, the charging must be interrupted and the truck

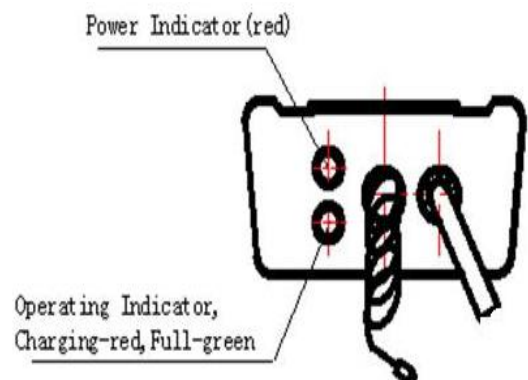

Fig. 14: LED- Status

must be started.

- Park the truck at a dedicated secured area with a dedicated power supply. Lower the forks and remove the load. Switch the truck off and connect the main power connector to the power supply. The charger starts charging the battery.

- This Charger features a three-stage charging function with automatic switching from 1st stage to the next stage.

The 1st stage: Constant current charging

The 2nd stage: Constant voltage charging

The 3rd stage: Floating charging

Following the increase of the electricity in the battery, the charging electrical current is reducing, the charger steps into the 3rd stage automatically.

A. SPECIFICATIONS

Input Volt: 150 – 260 V, AC 50 – 60 Hz

Output Volt: 145 V \pm 0.3

Output Current: 5 – 6 Amp

Applicable Ambient Temperature: –15 - +65°C

B. OPERATION

1. Insert the plug of the power cable into the socket of the power line.

1) Power Indicator lights (red)

2) Charging Indicator turns on red, indicating the battery is in charging.

2. When Charging Indicator turns from red to green, the battery is nearly full. Charging can continue in the Floating Stage.

3. When the battery is fully charged, disconnect the Power Cable from the Power Line.
+12 V Output Cable has power.

C. WARNING

1. During charging the truck can't be lifted electrically!

2. Do not use the truck in wet areas or conditions.

Table 3: Charging LED

LED- signal	Function
Red	Battery discharged
Green	Fully charged

When charging is finished, disconnect the connector from the socket and place it in the designated pocket.

d. Charging with external charger (only EBSL22N, optional)

The fully automatic external charger uses pulse charging. It can effectively alleviate the phenomenon of cell polarization, extend the service life of battery and has fast charge, slow charge and float charge

functions. It automatically selects the charging state according to the detected battery voltage and converts into floating charge state when the battery is fully charged.

Disconnect the Emergency plug and connect the charger plug with the battery sided connector. Connect the power cord of the charger to the main power supply. After switching on the charger, the charging starts automatically.

For further information read the instruction handbook of the external charger.

8. REGULAR MAINTENANCE



- Only qualified and trained personnel are allowed to do service on this truck.
- Before servicing the truck, remove the load and lower the forks to the lowest position.
- Completely immobilize the truck before working on components that might pinch fingers or hands if movement were allowed.
- Use approved and from your dealer released original spare parts.
- Please consider that oil leakage of hydraulic fluid can cause failures and accidents.
- It is allowed to adjust the pressure valve only from trained service technicians.
- Waste material like oil, used batteries or other must be probably disposed and recycled according to the national regulations and if necessary brought to a recycling company.
- All bushings and bearings have been lubricated at the factory. To increase their life, regular maintenance is recommended. Using the appropriate grease for the application and lubricate each grease fitting every 6 months.
- Harsh environments may require more frequent maintenance.

If you need to change the wheels, please follow the instructions above. The wheels must be round and they should have no abnormal abrasion. By changing the wheels secure the truck by using dedicated equipment.

a. Maintenance Checklist

DAILY

- Follow chapter 5.

MONTHLY

- All bearings and shafts are provided with long- life grease at the factory. Long-life grease should be applied to the lubrication points at monthly intervals or after each time the truck is cleaned.
- Clean off dirt and debris.

EVERY THREE MONTH

- Check the set-up of the drain-valve

ANNUALLY

- Change the oil (more frequently if color has substantially darkened or feels gritty). The required hydraulic fluid type is ISO VG32, its viscosity should be 30cSt at 40°C, total volume is about 1 - 1.3 l.
- Check all parts of the truck for wear and replace defective parts where necessary.

NOTE: If hydraulic oil is milky white in color, water is in the hydraulic system. Change the hydraulic oil immediately.

 Before operating the truck, ensure that all markings and decals are on the right place and not damaged (acc. to Fig. 3). If necessary replace the decals.

b. Deaeration of the hydraulic system

Air may find its way into the pump during transportation, tilting or usage on uneven ground. It can result in not elevating forks whilst pumping in the **Raise** position. The air can be removed in the following way: Move the control handle to the **Lower** position, move then the tiller down several times. Thereafter normal operation can be resumed.

c. Check and refill hydraulic oil

- Ensure forks are in lowered position.
- Lay pallet truck on either side. Position drain plug of hydraulic cylinder up.
- Remove the screw plug.
- Add hydraulic oil until level of oil is at bottom of hole.
- Replace drain plug, upright the truck

d. Checking electrical fuses

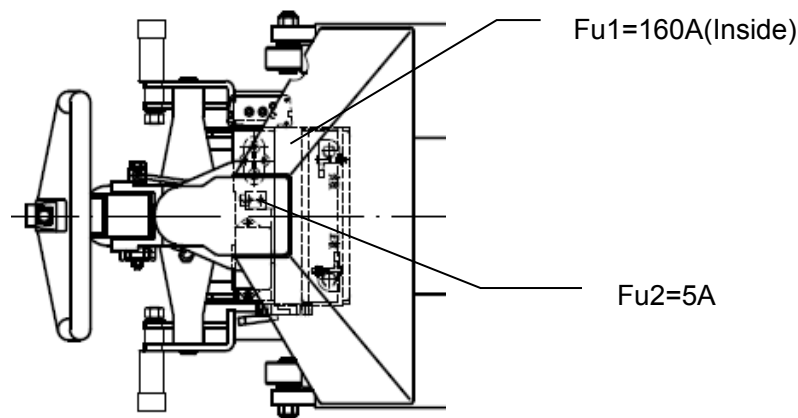

Fig.15: Overview

9. TROUBLE SHOOTING

 If the truck has malfunctions follow the instructions, mentioned under chapter 6f.

Table 2: Trouble shooting

No	Symptom	Possible Causes	Corrective action
1	Motor and	<ul style="list-style-type: none"> • Defective fuse FU1 or FU2 	<ul style="list-style-type: none"> • Replace the fuses

	hydraulic pump does not operate	<ul style="list-style-type: none"> • Loose or unconnected plug • Defect motor 	<ul style="list-style-type: none"> • Reconnect • Replace motor
2	The high-lift pallet truck does not lift the load, although the pump is working perfectly	<ul style="list-style-type: none"> • Load is too heavy, overload valve is actuated Control lever is out of adjustment. • Lowering valve does not close any more or the valve face is not sealed because of dirt piston rod to rust. • Electric circuit is disconnected • Electromagnetic contactor KM is defective • Lifting switch is obstructed resp. defective • Hydraulic pump does not work 	<ul style="list-style-type: none"> • Reduce the load • Clean or replace it • Check the wiring • Replace the contactor KM • Check resp. replace the lifting switch • Check the pump
3	Raised load is lowering automatically.	<ul style="list-style-type: none"> • Leakage in the hydraulic system • Lowering valve does not close any more or the valve unit is not sealed because of dirt • Incorrect valve set-up. • Pressure relief valve (pump) has leakage (pump turns slowly backwards.) 	<ul style="list-style-type: none"> • Replace the seal • Clean or replace the valve • Adjust the lowering valve
4	Oil loss on hydraulic cylinder	<ul style="list-style-type: none"> • Sealing worn out or defect 	<ul style="list-style-type: none"> • Replace the sealing
5	The raised load is lowered too slowly	<ul style="list-style-type: none"> • Temperature too low – the hydraulic system oil is too thick 	<ul style="list-style-type: none"> • Operate the truck in warmer locations.
6	Fork does not raise till upper position	<ul style="list-style-type: none"> • Insufficient oil in the tank • Battery discharged 	<ul style="list-style-type: none"> • Refill with oil (while the forks are lowered) • Charge the battery
7	Battery capacity to low	<ul style="list-style-type: none"> • Battery is not charged enough • Battery is defective 	<ul style="list-style-type: none"> • Recharge • Replace the battery
8	Battery cannot be charged	<ul style="list-style-type: none"> • Fuse FU2 is defective • Battery resp. charger defective 	<ul style="list-style-type: none"> • Replace FU2 • Replace battery resp. charger
9	Fast battery discharge	<ul style="list-style-type: none"> • Silted battery • Sulfating or other failure in the battery. • Accidental earth contact in the electric system or battery. 	<ul style="list-style-type: none"> • Replace battery • Repair or replace battery

10. HYDRAULIC FLOW DIAGRAM AND CIRCUIT DIAGRAM

a. Hydraulic flow diagram

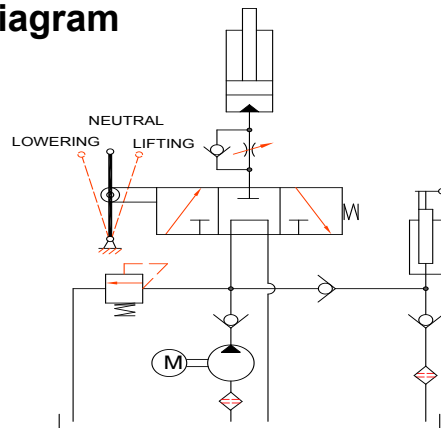

Fig.16: Hydraulic diagram (electric)

b. Circuit diagram (EBSL22N)

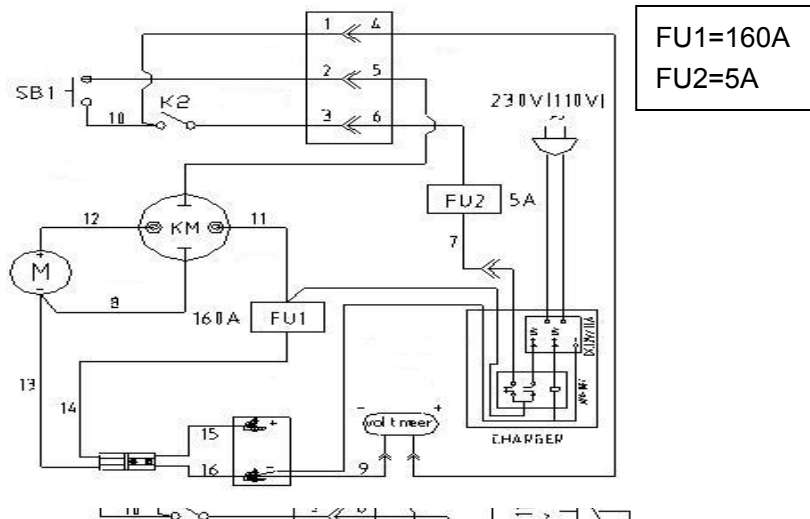

Fig.17: Electric diagram onboard charger

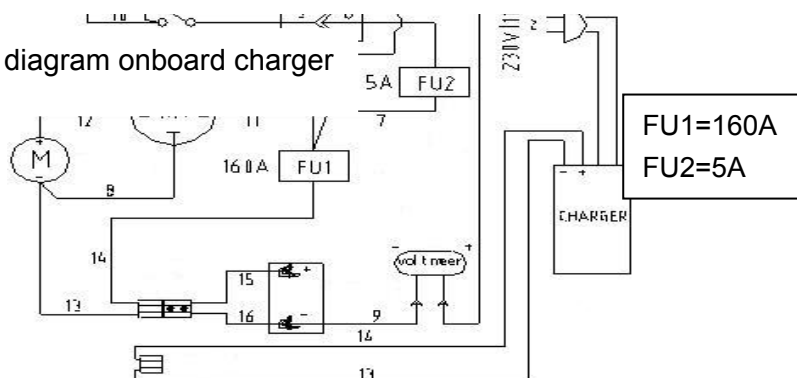

Fig.18: Electric diagram external charger

11. SPECIALIZED STIPULATIONS FOR THE US- AMERICAN MARKET

The content in this chapter is specialized for the US-American market.

a. Foreword/ Compliance

Operating this truck requires knowledge which can be acquired from this instruction handbook. This handbook must be kept available throughout the entire period of use of the truck.

YOU MUST BE TRAINED AND CERTIFIED TO OPERATE THIS TRUCK! READ AND OBEY ALL WARNINGS AND INSTRUCTIONS IN THIS MANUAL AND ON THE TRUCK!

Only properly trained operators are allowed to operate a powered industrial truck. Your employer must train you and certify, that you are qualified to operate this truck (required by OSHA § 1910.178). The training must satisfy OSHA requirements and as minimum the topics mentioned in this handbook. Depending on the context in this operating manual, the user can refer to several people, including the owner of the truck, anyone who leases or borrows this truck, and the operator as defined in ASME B56.1. Please pay attention to the section in ASME B56.1 concerning the operator. In this standard, it is defined that the safe operation is the responsibility of the operator (ASME B56.1-2003, Part II, section 5.1.1). You and others can be seriously injured or even killed if you don't use this truck correctly. Before operating your truck, inspect your truck and ensure that it is in correct working order. This truck was designed and built to current industry and government standards. For more information see following:

- ASME B56.1 (American Society of Mechanical Engineers)
- OSHA §1910.178 (Occupational Safety and Health Act)
- UL 583 (Underwriters Laboratory)
- ANSI Z535.4 (American National Standards Institute)

⚠ DANGER This sign indicates hazard situations, if not avoided, will result in serious injury or death. The instructions or precautions to this message must be observed to avoid the potential risk of injury or death.

⚠ WARNING If not followed, warning indicates hazard situations which may lead to moderate injury. The instructions or precautions to this message must be observed to avoid the potential risk of injury or death.



If not followed, caution indicated situations which may lead to minor injury. Instructions or precautions must be observed to avoid minor injury.

b. Description warning labels (only US-market)

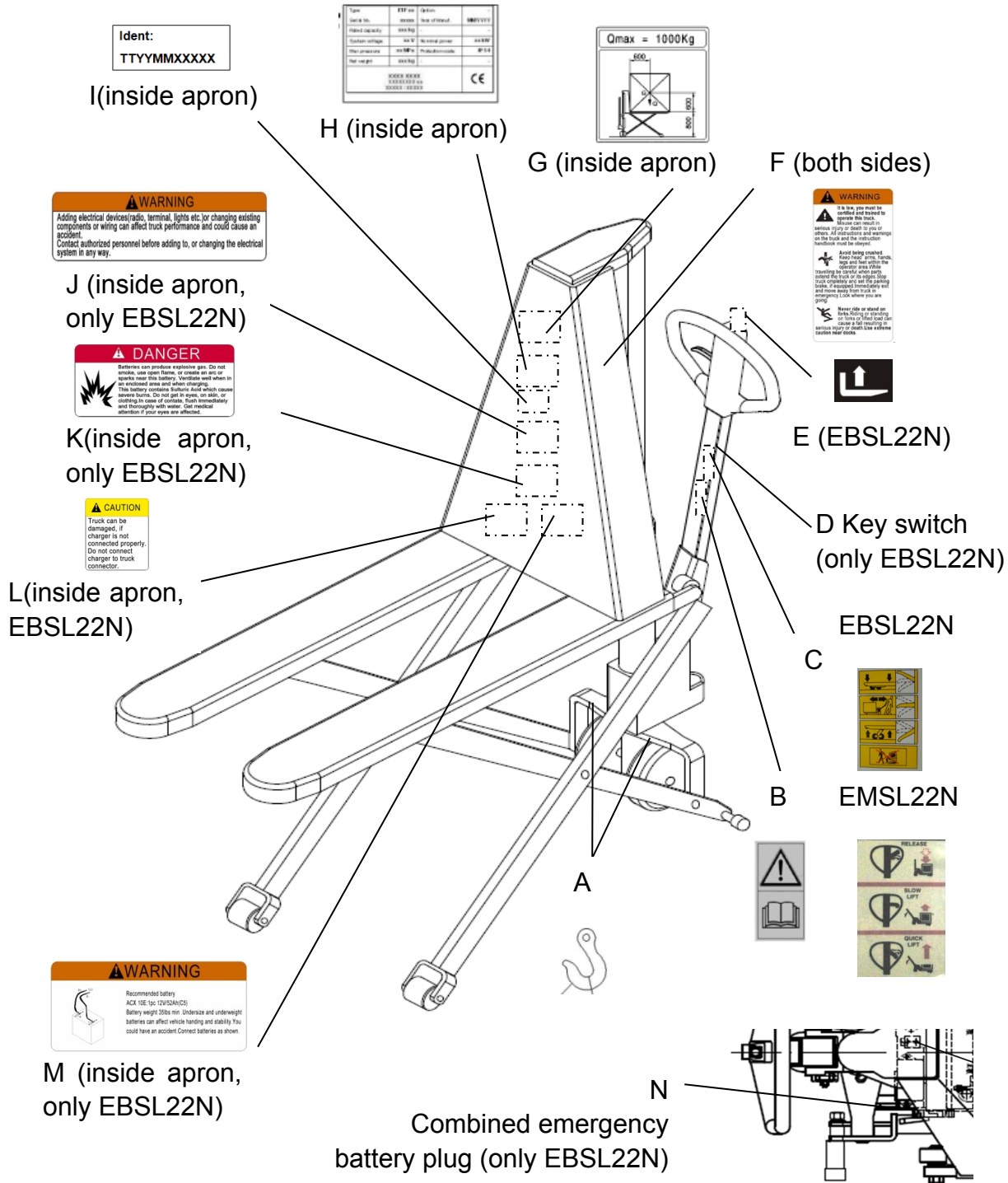

Fig.19: Decals for the US-market

- A Crane hook sign
- B Sign read and follow this instructions
- C Sign operating instruction
- D Key switch
- E Electric lifting
- F Sign warning stay clear stop truck
- G Sign capacity and load center

- H Identification plate (ID-Plate)
- I Truck identification plate number
- J Sign warning electrical devices
- K Sign danger battery
- L Sign caution charger
- M Sign warning battery size
- N Combined emergency battery plug

Decals on your truck according to chapter 2c:

Crane hook sign (A)



Sign warning electrical devices (J, only EBSL22N)

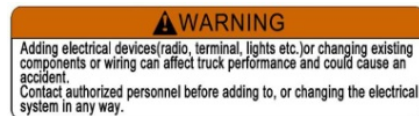

Sign read and follow this instruction (B)



Sign danger battery (K, only EBSL22N)



Sign operating instruction (C)

EMSL22N EBSL22N

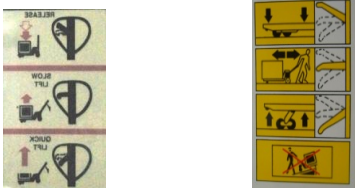

Electric lifting (E, Only EBSL22N)



Sign caution charger (L, only EBSL22N)



Sign warning battery size (M, only EBSL22N)



Sign stop

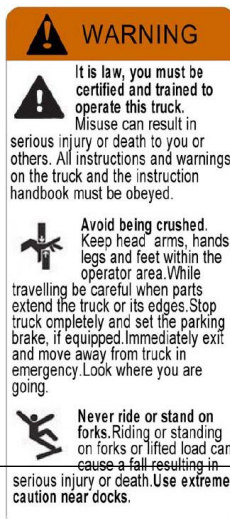

warning stay clear truck (F)

Sign capacity

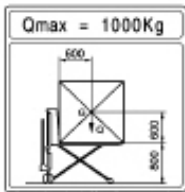

enter (G)

WARNING

Recommended battery
AGM 110 19c 12V52Ah(C2)
Battery weight 350kg min. Undersize and underweight
batteries can affect vehicle handling and stability. You
could have an accident. Connect batteries as shown.

3. 12. DECLARATION OF CONFORMITY (valid, if sold within the EU)

[GB] CE Declaration of Conformity

The signatory hereby declares that the specified machine conforms to the EU Directive 2006/42/EC (Machine Directive) and 2004/108/EEC (Electromagnetic Compatibility, EMC) including their amendments as translated into national legislation of the member countries. The signatory is individually authorized to compile the technical documents.

[D] EG-KONFORMITÄTSERKLÄRUNG

Der Unterzeichner bescheinigt hiermit, dass die im Einzelnen bezeichnete Maschine den Europäischen Richtlinien 2006/42/EG (Maschinenrichtlinie) und 2004/108/EWG (Elektromagnetische Verträglichkeit - EMV) einschließlich deren Änderungen sowie dem entsprechenden Rechtsersatz zur Umsetzung der Richtlinien in nationales Recht entspricht. Der Unterzeichner ist bevollmächtigt, die technischen Unterlagen zusammenzustellen.

[E] DECLARACIÓN DE CONFORMIDAD CE

El signatario certifica por medio de la presente que la máquina especificada cumple con las Normas Europeas 2006/42/CE (Normativa para maquinarias) y 2004/108/CE (Compatibilidad electromagnética), incluyendo sus respectivas modificaciones, así como con el decreto-ley para la adaptación de las normas al derecho nacional. El signatario dispone de una autorización individual que le permite compilar la documentación técnica.

[F] DECLARATION DE CONFORMITE CE

Par la présente déclaration, les soussignés certifient que le machines spécifiée ci-dessus est conforme à la loi et aux directives européennes 2006/42/CE (directive sur les machines) et 2004/108/CEE (compatibilité électromagnétique - CEM), y compris aux modifications qui y sont apportées et à l'arrêté autorisant sa transposition en droit national. Chaque signataire est habilité à établir individuellement la documentation technique.

[NL] EG-KONFORMITEITSVERKLARING

Ondergetekenden verklaren hierbij dat - volgens de nationale wetgeving van de Lidstaten - de hierboven vermelde opgegeven machina beantwoordt aan de bepalingen qua veiligheid bij machines (EG richtlijn 2006/42/EC) en electro-magnetische compatibiliteit (EG richtlijn 2004/108/EEC).

Ondergetekenden zijn ieder individueel gemachtigd het technisch dossier samen te stellen.

[P] DECLARAÇÃO DE CONFORMIDADE CE

Pela presente, os signatários certificam que o máquina especificado está conforme às Directivas Europeias 2006/42/CE („Máquinas“) e 2004/108/CEE („Inocuidade Electromagnética - IEM“), incluindo as alterações das mesmas e o respectivo decreto-lei para a transposição em lei nacional. Cada um dos signatários está autorizado a proceder à elaboração da documentação técnica.

[I] DICHIARAZIONE DI CONFORMITÀ CE

I sottoscritti dichiarano che il veicolo per trasporti interni a macchina specificato soddisfa le Direttive Europee 2006/42/EC (Direttiva Macchine) e 2004/108/EEC (Compatibilità elettromagnetica - EMV) comprese le relative modifiche, come pure il rispettivo decreto legislativo per la conversione delle direttive in diritto nazionale. I sottoscritti sono singolarmente autorizzati alla creazione della documentazione tecnica.

[BG] ЕВРОПЕЙСКА ОБЩНОСТ - ДЕКЛАРАЦИЯ ЗА СЪОТВЕТСТВИЕ

Подписаните удостоверяват с настоящето, че подробно описаното машина средство отговаря на европейския норматив 2006/42/EG (норматив за машини) и на 2004/108/EG (електро-магнетична съвместимост), включително с техните промени, както и на съответния указ за прилагане на нормативите в националното право. Подписаните при това са упълномощени поотделно да съставят техническата документация.

[CZ] EG - PROHLÁŠENÍ O SHODĚ

Niže podepsaný tímto potvrzuje, že podrobný popis uvedené stroje odpovídá Evropským směrnici 2006/42/EC (směrnice pro stroje) a 2004/108/EEC (elektromagnetická interference - EMV) včetně jejich pozdějších úprav, jakož i příslušným právním výnosům pro uplatnění příslušné směrnice v rámci národního práva. Každý z podepsaných jsou jednotlivě způsobilí k vytvoření technických podkladů.

[DK] EF-OVERENSSTEMMELSEERKLÆRING

Undertegnede atterer hermed, at det specificerede maskine stemmer overens med de Europæiske Direktiver 2006/42/EU (maskindirektiv) og 2004/108/EØF (elektromagnetisk kompatibilitet - EMC) samt med den modsvarende lovgivning til implementering af direktiver i den nationale lovgivning. De undertegnede er hver for sig beføjede til at sammenstille de tekniske dokumenter.

[EST] EL vastavusavaldus

Allakirjutatud tõendavad käesolevaga, et üksikasjaliselt kirjeldatud täpsustatud masin vastab Euroopa direktiividele 2006/42/EÜ (Direktiiv masinate kohta) ja 2004/108/EMÜ (Elektromagnetilise sobivus - EMS) kaasa arvatud nende muudatused ja nendele vastavatele õigusmäärustele direktiivide muutmiseks siseriiklikuks õiguseks. Iga allakirjutanu üksikult on volitatud koostama tehnilist dokumentatsiooni.

[FIN] EU-YHDENMUKAISUUSSELÖSTUS

Allakirjoittaneet todistavat täten, että kukin erikseen mainittu omalla voimainlähteellä varustettu tehdaskone vastaa EU-direktiivien 2006/42/EC (koneenrakennusdirektiivi) ja 2004/108/EEC (sähkömagneettinen yhteensopivuus – EMC) määräyksiä sekä niiden muutoksia ja niiden kansalliseen lainsäädäntöön soveltamista koskevaa oikeussäätöä. Jokaisella allekirjoittaneista on oikeus itsenäisesti laatia asiaankuuluvia teknisiä asiakirjoja.

[GR] ΔΗΛΩΣΗ ΣΥΜΜΟΡΦΩΣΗΣ ΕΟΚ

Οι υπογράφωντες βεβαιώνουν διά της παρούσης ότι το συγκεκριμένο μηχάνημα συμμορφώνεται προς την Κοινοτική Οδηγία 2006/42/ΕΚ («Μηχανήματα») και 2004/108/ΕΟΚ (Ηλεκτρομαγνητικής Συμβατότητας, ΗΜΣ), καθώς και οι τροποποιήσεις τους, όπως μεταφράστηκε στην εθνική νομοθεσία των χωρών μελών. Οι υπογράφωντες είναι σε κάθε περίπτωση εξουσιοδοτημένοι ατομικά να καταρτίσουν τα τεχνικά έγγραφα.

[H] EU KONFORMITÁSI NYILATKOZAT

Alulírottak ezennel igazolják, hogy a részletesen leírt a megadott gép megfelel a 2006/42/EC (Gép-Irányelv) és a 2004/108/EEC (Elektromágneses összeférhetőség - EMV) Európai Irányelveknek, beleértve azok módosításait, valamint az irányelvek nemzeti jogba történő átültetésére irányuló megfelelő jogi rendelkezést. Továbbá az alulírottak mindegyike rendelkezik meghatalmazással arra nézve, hogy összeállíthatja a műszaki dokumentációt.

[LT] ES atitikimø deklaracija

Žemiau pasirašę asmenys patvirtina, kad atskirai aprašytas nurodyta mašina atitinka Europos Sąjungos direktyvas 2006/42/EB (Mašinų direktyva) ir 2004/108/EEB (Elektromagnetinis suderinamumas – EMS) įskaitant jų pakeitimus, o taip pat ir atitinkamą teisės aktą dėl direktyvų įgyvendinimo nacionalinėje teisėje. Kiekvienas iš pasirašusių asmenų turi teisę ruošti techninę dokumentaciją.

[LV] ES atbilstības deklarācija

Ar zemāk redzamajiem parakstiem tiek apliecināts, ka norādīts mašīna atbilst Eiropas Savienības normatīvam 2006/42/EG (Mašīnu normatīvas) un 2004/108/EWG (Elektromagnētiskā atbilstība – EMV), ieskaitot to izmaiņas, kā arī atbilstošos tiesiskos rīkojumus normatīvu pielāgošanai nacionālajai likumdošanai. Parakstu īpašnieki ir atsevišķi pilnvaroti sastādīt tehniskās dokumentācijas.

[N] EU-KONFORMITETSERKLÆRING

Undertegnede bekrefter hermed at de enkelte betegnede maskin med kraftdrift tilsvarende de europeiske retningslinjerne 2006/42/EC (maskinretningslinje) og 2004/108/EEC (elektromagnetisk fordraglighed - EMV) inklusiv disse endringer og den tilsvarende rettsforordning til omsetning av nasjonal rett. Hver undertegnede er fullmektig til å sette sammen de tekniske dokumentene.

[PL] DEKLARACJA ZGODNOŚCI WE

Niżej podpisani deklarują, że poniżej opisana maszyna spełnia wymagania określone w dyrektywach Europejskich 2006/42/EC (Dyrektywa Maszynowa) i 2004/108/EEC (Kompatybilności elektromagnetycznej - EMC) wraz z ich późniejszymi zmianami oraz odpowiednimi rozporządzeniami mającymi na celu przeniesienie tych dyrektyw do prawa krajów członkowskich. Sygnatariusz jest indywidualnie upoważniony do zestawiania dokumentacji technicznej.

[RO] DECLARAȚIE DE CONFORMITATE CE

Subsemnatii adevăresc prin prezenta că vehiculul de specificat mașină descris individual corespunde directivelor europene 2006/42/CE (Directiva privind mașinile) și 2004/108/CEE (Compatibilitatea electromagnetică - CEM) inclusiv modificărilor lor precum și actului legislativ corespunzător pentru transpunerea directivelor în drept național. Subsemnatii sunt fiecare în parte împuterniciți să întocmească documentația tehnică.

[RUS] Декларация соответствия стандартам ЕС

Настоящим лица, подписавшие документ, удостоверяют, что машина с указанной спецификацией соответствует европейским стандартам 2006/42/EG (Транспортная директива) и 2004/108/EWG (Электромагнитная совместимость - EMC), включая изменения в них, а также соответствующим национальным стандартам и нормам. Каждое по отдельности лицо, подписавшее документ, имеет полномочия для составления технической документации.

[S] EG-KONFORMITETS FÖRKLARING

Undertecknarna intygar härmed att det i detalj betecknade maskin uppfyller de Europeiska direktiven 2006/42/EG (Maskindirektiv) och 2004/108/EEG (Elektromagnetisk tålighet - EMV), inklusive ändringarna i detta och den motsvarande rättsförordningen för att omsätta direktiven i nationell rätt. Undertecknarna har var för sig fullmakt att sammanställa den tekniska dokumentationen.

[SK] vyhlásenie o zhode

Dolu podpísaní týmto potvrdzujeme, že podrobný popis uvedené stroje zodpovedá Európskym smerniciam 2006/42/EC (ernica pre stroje) a 2004/108/EWG (elektromagnetická tolerancia – EMV) vrátane jeho neskorších úprav, rovnako zodpovedá aj príslušným právnym nariadeniam na uplatnenie smerníc v rámci národného práva. Každý z podpísaných je jednotlivo splnomocnený na vytvorenie technických podkladov.

[SLO] EU IZJAVA O SKLADNOSTI

Podpisani s tem potrjujejo, da posamično označeno določeno stroj vozilo odgovarja Evropski direktivi 2006/42/EC (Direktiva o strojih) in 2004/108/EEC (Elektromagnetna skladnost - EMV) vključno z njihovimi spremembami ter ustrezno pravno uredbo o prevzemu smernic v nacionalno pravo. Podpisniki so vsakokrat posamezno pooblašteni za izdajanje tehnične dokumentacije.

[TR] AB Uygunluk Açıklaması

İmza sahibi şahıslar, ayrıntıları belirtilen makine aracının, 2006/42/EC (Makine Yönergesi) ve 2004/108/EEC (Elektromanyetik Uyumluluk – EMC) no'lu Avrupa Yönergelerine ve bunların değişiklik sonucu oluşan metinlerine ve yönergelerin milli hukuk hükümlerine dönüştürülmesine dair ilgili hukuk kararına uygun olduğunu tasdik ederler. İmza sahibi şahıslar teknik dosyaları bir araya getirmek için münferiden vekil tayin edildi.

- (1) Type/ Typ/ Tipo/ Modello/ Тууып/ Tipo / ΤΥΠΟΣ/ Τίπος/ Тір/ Тип/ Tips/ Тіпас/ Tüüp:
- (2) Serial No./ Serien-Nr./ N°. de série/ Seriennummer/ N° de serie/ Numero di serie/ Serienr./ Sarjanro/ αριθμός/ Seriové číslo/ Szériaszám/ Nr. Seryjny/ Serijska številka/ Výrobné číslo/ Серийный номер/ Seri No./ Seerianr./ Sērijas Nr./ Serijos numeris:
- (3) Year of constr./ Baujahr/ Année de constr./ Bouwjaar/ Año de constr./ Anno di costruzione/ Produktionsår/ Byggeår/ Tillverkningsår/ Valmistusvuosi / Ano de fabrico / έτος κατασκευής/ Rok výroby/ Gyártási év/ Rok produkcji / Letnik / Год изготовления / Üretim yılı / Väljålskeasta / Izgatavošanas gads / Gamybosmetai
- (4) Manufacturer or his authorized representative in Community/ Hersteller oder in der Gemeinschaft ansässiger Vertreter/ Fabricant ou son mandataire établi dans la Communauté/ Fabrikant of zijn in de Gemeenschap gevestigde gemachtigde/ Fabricante o representante establecido en la Comunidad/ Construtor ou Representante estabelecido na Comunidade/ Costruttore oppure il suo rappresentante nella Comunità/ Fabrikant eller dennesi Fællesskabet etablerede befuldmægtigede/ Produsent eller agent innen felleskapet/ Tillverkare eller representant inom EU/ Valmistaja tai yhteisömaassa oleva edustaja / V`robce nebo jeho zastoupení/ Gyártó / producent albo jego przedstawiciel w EG (Wspólnota Europejska)/ Κατασκευαστής ή όκηνη ηνπηθώλ αληηπινζώπσλ/ Üretici ya da Bölgedeki Yetkili Temsilci/ Proizvajalec ali pooblašteni zastopnik s sedežem v EU/ Výrobca alebo zástupca so stálym bydliskom v EÚ / Изготовитель или его представитель, зарегистрированный в стране Содружества/ Tootja või organisatsioonis paiknev esindaja/ Ražotājs vai vietējais uzņēmuma pārstāvis / Gamintojas arba šalyje reziduojantis atstovas:
- (5) Date/ Datum/ Data/ Fecha/ datum/ Dato/ päiväys/ Datums/ дата / Dátum/ dátum/ tarih/ ημερομηνία
- (6) Authorised signatory/ Im Auftrag/ pour ordre/ Incaricato/ Por orden de/ por procuração/ op last van/ på vegne af/ på oppdrag/ Etter oppdrag/ psta./ Ülesandel / pavedus / v.i. / По поручению / megbízásából / дл`жностно лице / z pověření / z poverenia / po nalogu / na polecenie / din sarcina / adina / θαη' εληνη

(1) Type: **XX XX – Self-propelled industrial truck**

(2) Serial No: **XXXXXXXX**

(3) Year of constr.: **YYYY**

(4) Manufacturer or his authorized representative in Community:
Company name/ Street / Postal code Town/ Country

(5) Date: **YYYY-MM-DD**

(6) Authorized signatory: **Mr. Sample**

*Sample
If you can read this text,
your declaration is not complete.
In this case please ask for a copy*



MOBILE INDUSTRIES, INC.
3750B Laird Rd - Unit 2 & 3
Mississauga ON, L5L 0R6
Canada

Toll Free: 1 800 527 4612 • Local 905 279 5370
Email: info@mobilept.com

MOBILEPT.COM